

NOTES:

1. OCTANE P/N: 103926-001
2. TRACEABILITY: OCTANE S/N
3. ALL DIMENSIONS IN PARENTHESES () ARE REFERENCE ONLY.
4. PART MARKING: OCTANE MODEL NUMBER LABEL
5. FREQUENCY RANGE: 1350-1525 MHz
6. WEIGHT: 27.5 OZ

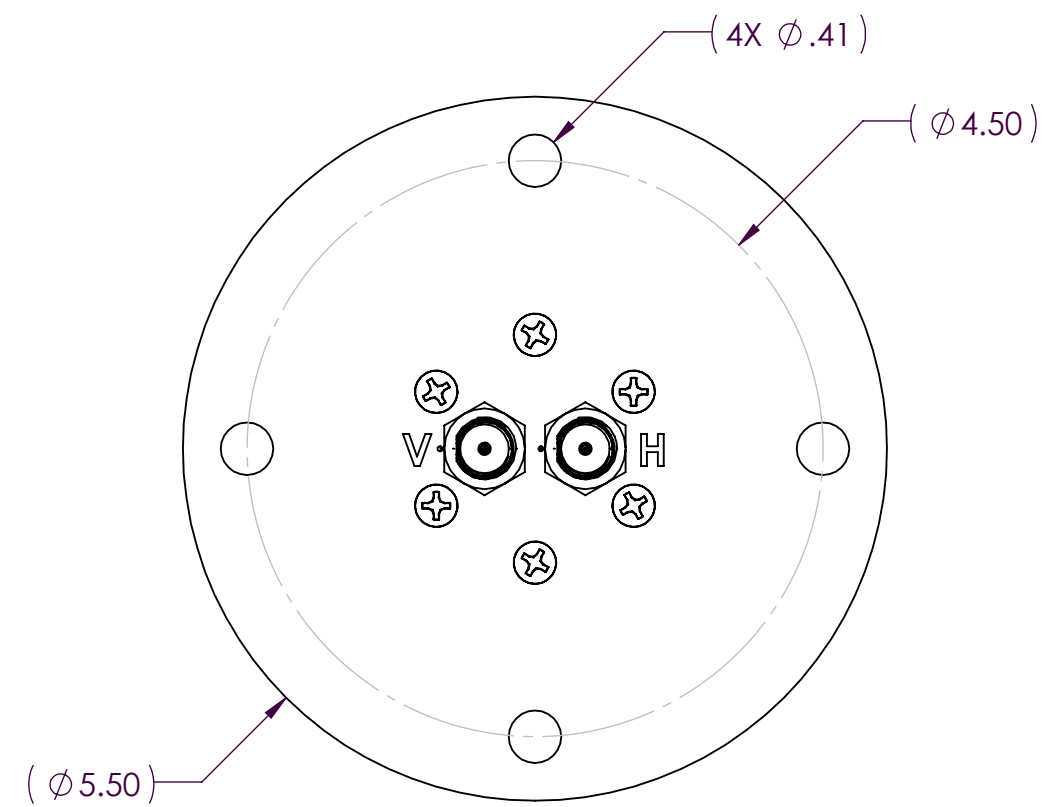

BOTTOM VIEW

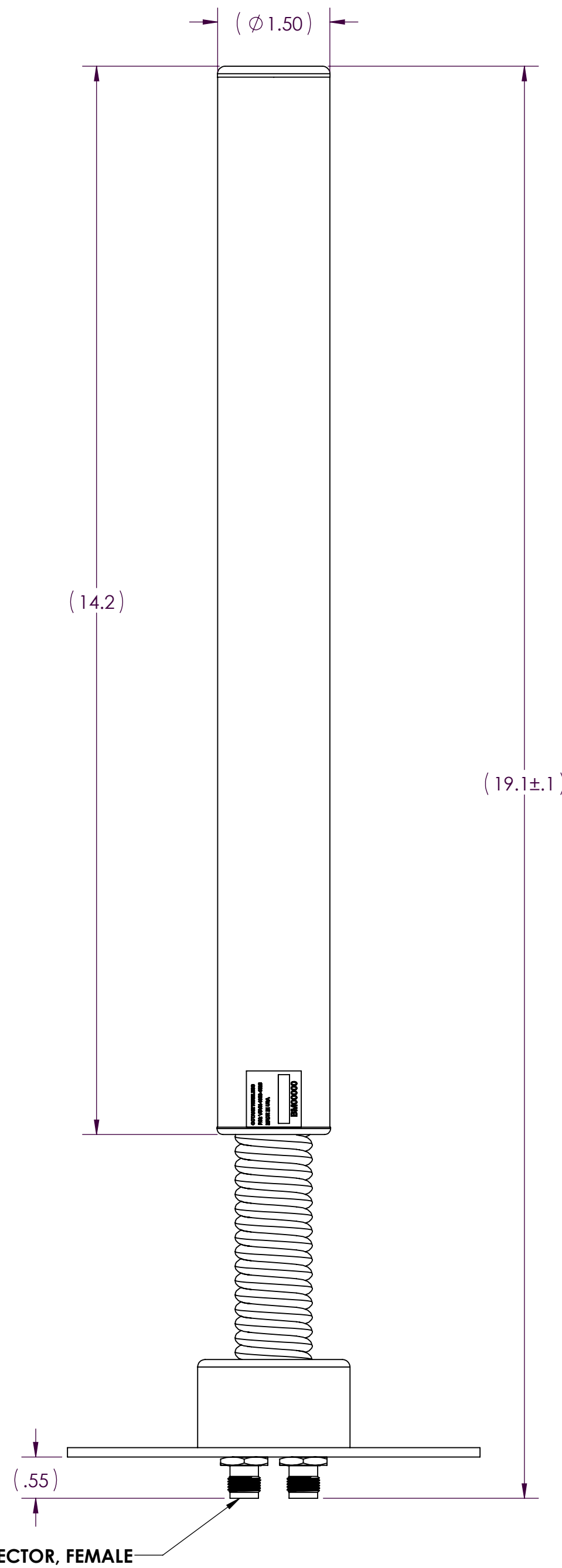

FRONT VIEW

REVISIONS				
ZONE	REV.	DESCRIPTION	DATE	APPROVED
N/A	X1	INITIAL RELEASE	12/11/2023	DJD
N/A	X2	ADDED CONFIG -001 & -002	12/13/2023	DJD
N/A	A	INITIAL RELEASE	2/14/2024	DJD

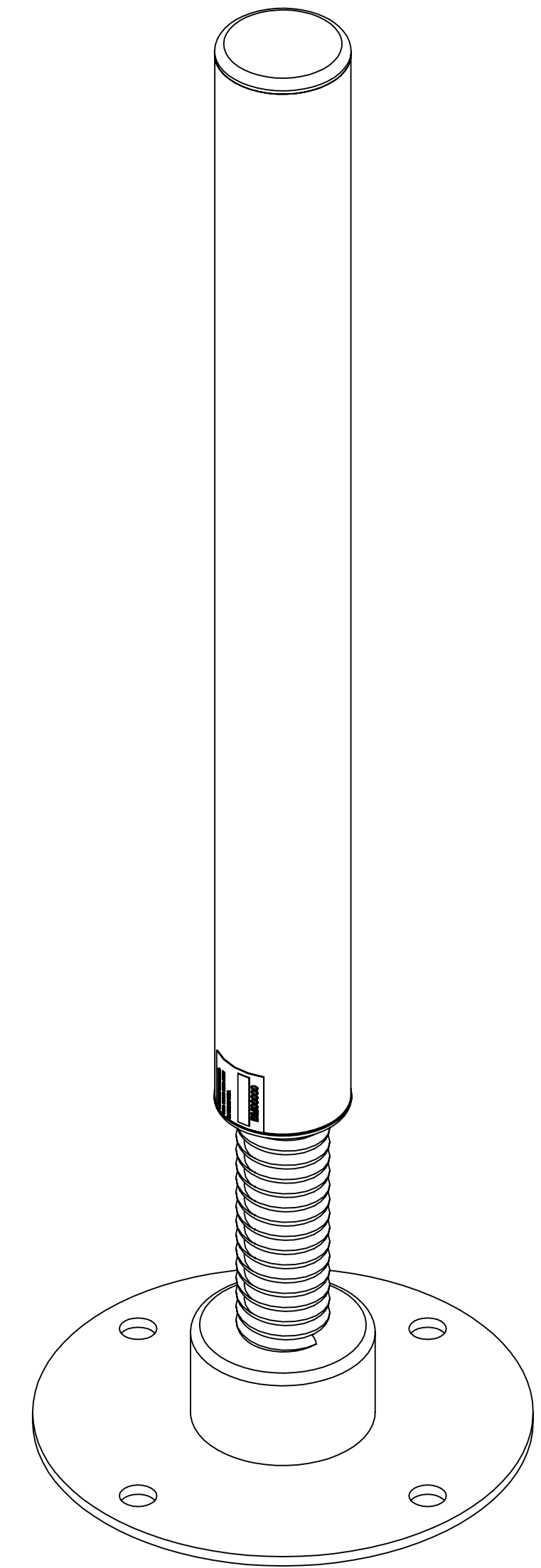

ISO VIEW

<p>THIRD ANGLE PROJECTION</p> <p>PROPRIETARY AND CONFIDENTIAL THE INFORMATION CONTAINED IN THIS DRAWING IS THE SOLE PROPERTY OF OCTANE WIRELESS. ANY REPRODUCTION IN PART OR AS A WHOLE WITHOUT THE WRITTEN PERMISSION OF OCTANE WIRELESS IS PROHIBITED.</p>	<p>UNLESS OTHERWISE SPECIFIED: DIMENSIONS ARE IN INCHES TOLERANCES: TWO PLACE DECIMAL \pm.010 THREE PLACE DECIMAL \pm.005 ANGULAR \pm1°</p>	<table border="1"> <tr> <th>NAME</th> <th>DATE</th> </tr> <tr> <td>DRAWN DJD</td> <td>11/13/23</td> </tr> <tr> <td>CHECKED AR</td> <td>11/13/23</td> </tr> <tr> <td>ENG APPR. DN</td> <td>11/13/23</td> </tr> <tr> <td>MFG APPR. AF</td> <td>11/13/23</td> </tr> </table>	NAME	DATE	DRAWN DJD	11/13/23	CHECKED AR	11/13/23	ENG APPR. DN	11/13/23	MFG APPR. AF	11/13/23	<p>OCTANE WIRELESS 1340 CHARWOOD ROAD, SUITE L HANOVER, MD 21076</p>
	NAME	DATE											
	DRAWN DJD	11/13/23											
	CHECKED AR	11/13/23											
ENG APPR. DN	11/13/23												
MFG APPR. AF	11/13/23												
<p>MATERIAL SEE NOTES</p>	<p>COMMENTS:</p>	<p>TITLE: ASSEMBLY, VEHICLE SPRING ANTENNA, 1350-1525 MHz, DUAL POL, DUAL TNC FEMALE CONNECTOR</p>	<p>SIZE DWG. NO. REV C VSVH-1350-1525 A</p>										
<p>FINISH SEE NOTES</p>	<p>DO NOT SCALE DRAWING</p>	<p>SHEET SCALE 1:4</p>	<p>SHEET 1 OF 1</p>										