

NOTES:

1. PHARAD P/N: 101093
2. TRACEABILITY: PHARAD S/N LABEL
3. FREQUENCY OF OPERATION: 1600-5900 MHz
4. WEIGHT: 7 OZ
5. PART MARKING: PHARAD MODEL NUMBER LABEL

REVISIONS				
ZONE	REV.	DESCRIPTION	DATE	APPROVED
N/A	A-01	RELEASE TO MANUFACTURING	8/27/2013	DJG

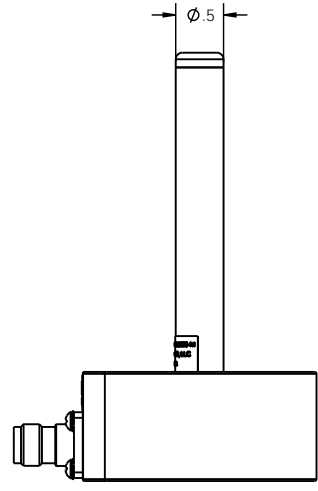
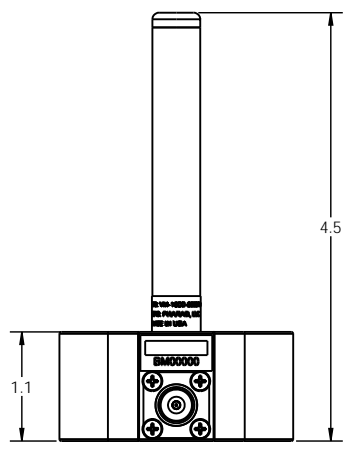
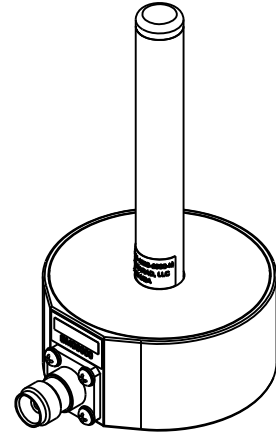
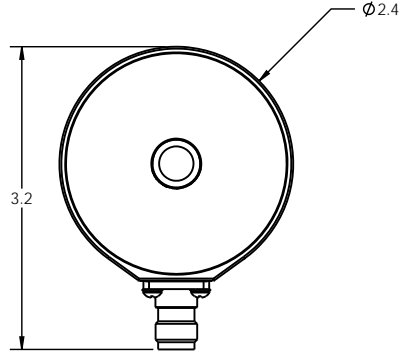

CAUTION: BASE CONTAINS STRONG MAGNETS

PROPRIETARY AND CONFIDENTIAL
 THE INFORMATION CONTAINED IN THIS DRAWING IS THE SOLE PROPERTY OF PHARAD, LLC. ANY REPRODUCTION IN PART OR AS A WHOLE WITHOUT THE WRITTEN PERMISSION OF PHARAD, LLC IS PROHIBITED.

UNLESS OTHERWISE SPECIFIED:		NAME	DATE	PHARAD, LLC 1340 CHARWOOD ROAD, SUITE L HANOVER, MD 21076
DIMENSIONS ARE IN INCHES		DRAWN	DJG	8/27/2013
TOLERANCES:		CHECKED	HJJ	8/27/2013
TWO PLACE DECIMAL ±.010		ENG APPR	DN	8/27/2013
THREE PLACE DECIMAL ±.005		MFG APPR	AF	8/27/2013
ANGULAR ±1°		TITLE: ASSEMBLY, MAGNET MOUNT, 1600-5900 MHz		
MATERIAL		COMMENTS:		
SEE NOTES		SIZE DWG. NO. REV		
FINISH		C VM-1600-5900-M A-01		
SEE NOTES		SHEET 1 OF 1		
DO NOT SCALE DRAWING				