

NOTES:

1. OCTANE WIRELESS P/N: 103257
2. TRACEABILITY: OCTANE WIRELESS S/N
3. PART MARKING: OCTANE WIRELESS P/N
4. FREQUENCY OF OPERATION: 1350-1390 MHz
5. WEIGHT: 14 OZ

REVISIONS				
ZONE	REV.	DESCRIPTION	DATE	APPROVED
N/A	A	ENG RELEASE	11/13/2019	BZG

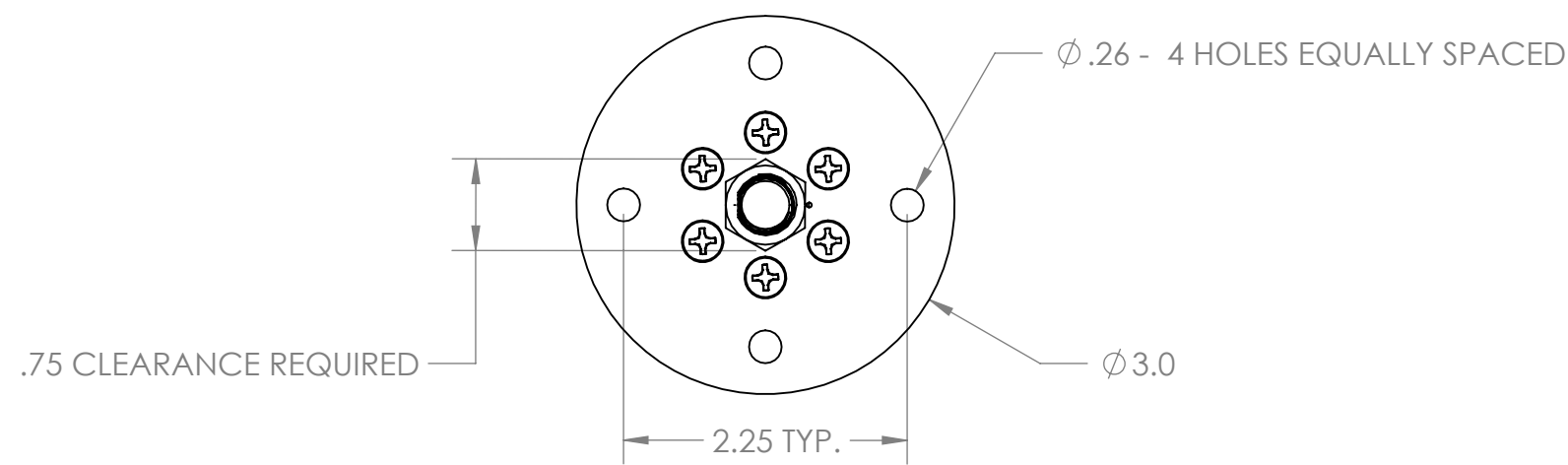
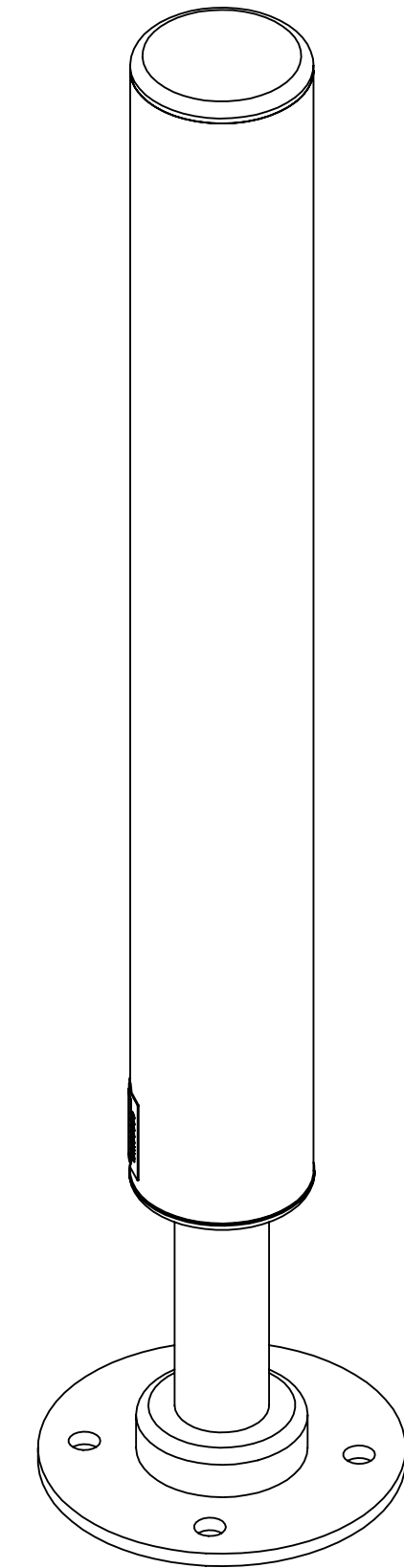
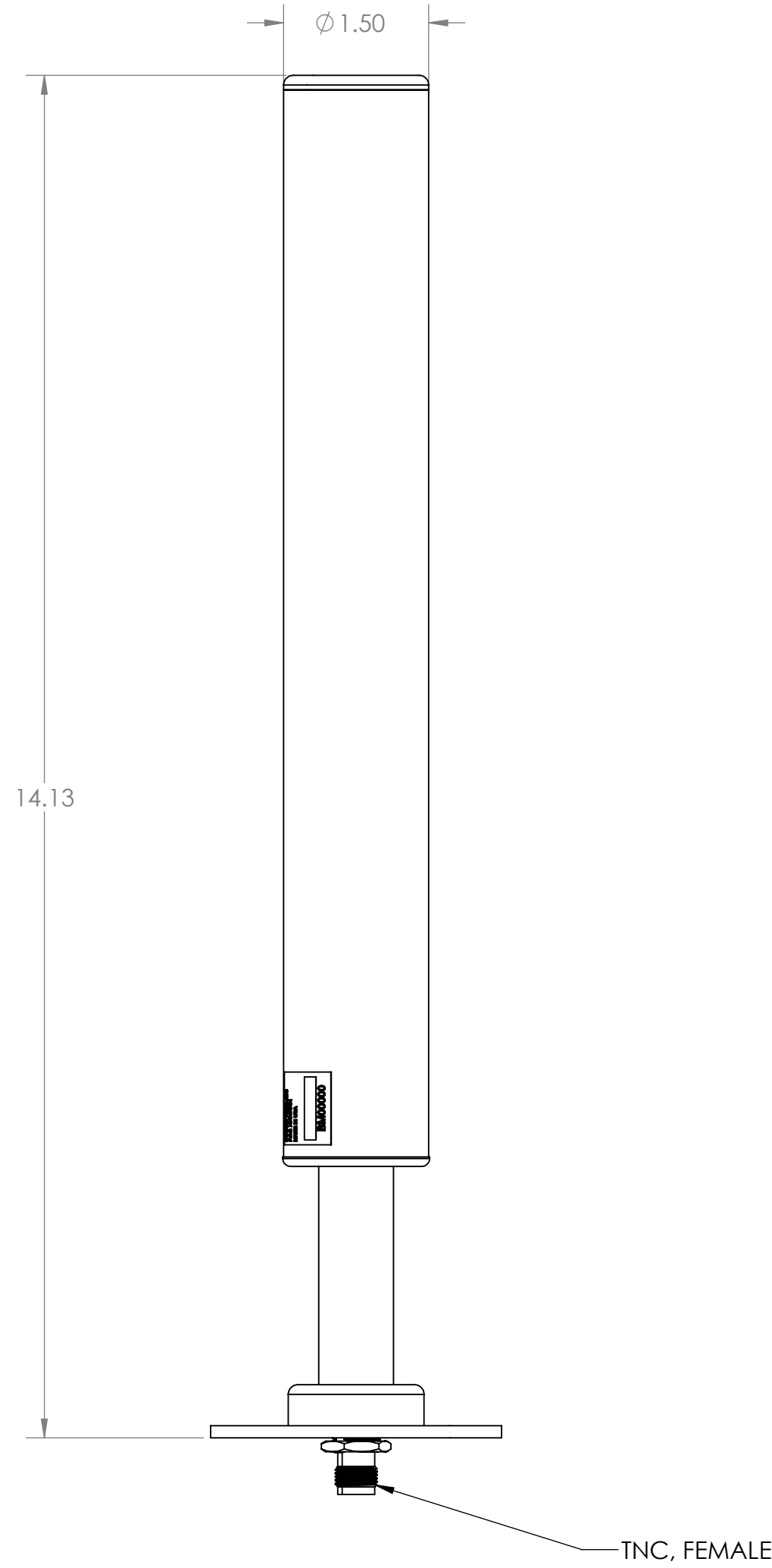

PROPRIETARY AND CONFIDENTIAL
 THE INFORMATION CONTAINED IN THIS DRAWING IS THE SOLE PROPERTY OF PHARAD, LLC. ANY REPRODUCTION IN PART OR AS A WHOLE WITHOUT THE WRITTEN PERMISSION OF PHARAD, LLC IS PROHIBITED.

UNLESS OTHERWISE SPECIFIED:	NAME	DATE	OCTANE WIRELESS 1340 CHARWOOD ROAD, SUITE L HANOVER, MD 21076	
DIMENSIONS ARE IN INCHES	DRAWN	BZG		11/13/2019
TOLERANCES: TWO PLACE DECIMAL ±.010 THREE PLACE DECIMAL ±.005 ANGULAR ±1°	CHECKED			
MATERIAL	ENG APPR.			
SEE NOTES	MFG APPR.			
FINISH	COMMENTS:			
SEE NOTES				
DO NOT SCALE DRAWING				

TITLE:
 ASSEMBLY, VEHICLE MOUNT
 SPRING ANTENNA, 1350-1390
 MHz, HP, TNC FEMALE, 5 dBi

SIZE DWG. NO. REV
C VSH-1350-1390 **A**