

NOTES:

1. PHARAD P/N: 101000
2. FINISH: URETHANE CARC COATING (MIL-DTL-53039), DESERT TAN
3. TRACEABILITY: PHARAD S/N
4. PART MARKING: PHARAD LABEL 101164-001
5. FREQUENCY OF OPERATION: 200-6000 MHz
6. WEIGHT: 16 LBS

REVISIONS				
ZONE	REV.	DESCRIPTION	DATE	APPROVED
N/A	A-02	ENGINEERING PROTOTYPE	3/1/2011	JDM

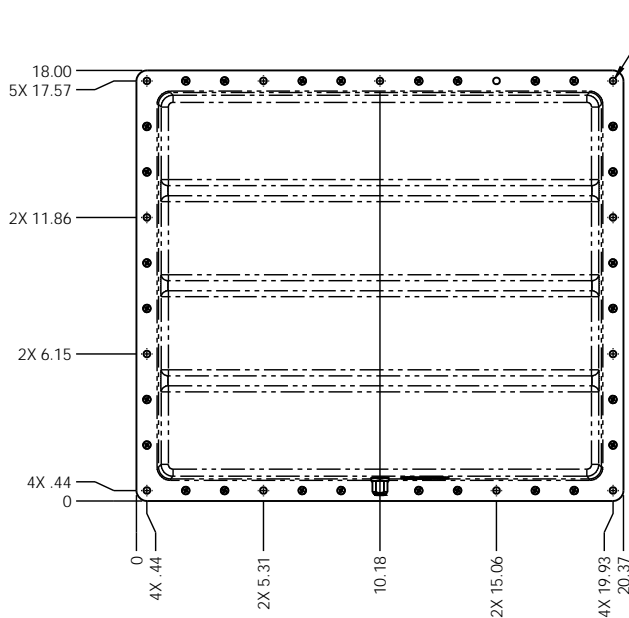

MOUNT ANTENNA TO VEHICLE DOOR USING
13 1/4-20 HEX HEAD MACHINE SCREWS

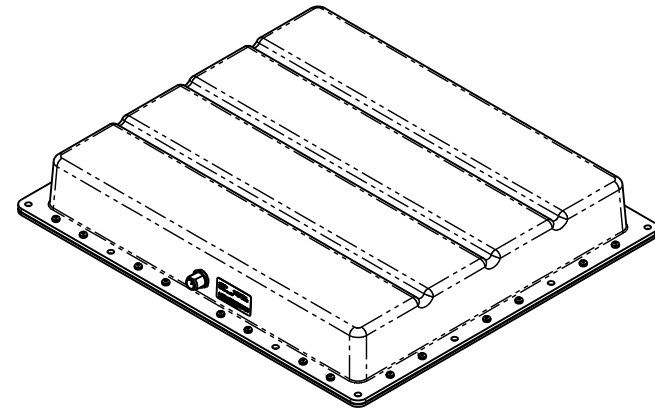

N-TYPE CONNECTOR, FEMALE



PROPRIETARY AND CONFIDENTIAL
THE INFORMATION CONTAINED IN THIS DRAWING IS THE SOLE PROPERTY OF PHARAD, LLC. ANY REPRODUCTION IN PART OR AS A WHOLE WITHOUT THE WRITTEN PERMISSION OF PHARAD, LLC IS PROHIBITED.

UNLESS OTHERWISE SPECIFIED: DIMENSIONS ARE IN INCHES		NAME	DATE	PHARAD, LLC 197 CROMWELL PARK DRIVE, SUITE V GLEN BURNIE, MD 21061	
TOLERANCES: TWO PLACE DECIMAL ±.010 THREE PLACE DECIMAL ±.005 ANGULAR ±1°		DRAWN	JDM		3/1/2011
MATERIAL		CHECKED	DT		3/3/2011
SEE NOTES		ENG APPR	RW		3/3/2011
FINISH		MFG APPR:		TITLE: ASSEMBLY, LOW PROFILE TACTICAL VEHICLE MOUNT ANTENNA, 200 - 6000 MHz	
DO NOT SCALE DRAWING		COMMENTS:			
SCALE: 1:4		SHEET 1 OF 2			
SIZE		DWG. NO.		REV	
C		VM-200-6000		A-02	