

NOTES:

1. OCTANE P/N: 101093
2. TRACEABILITY: OCTANE S/N
3. ALL DIMENSIONS IN PARENTHESES () ARE REFERENCE ONLY.
6. PART MARKING: OCTANE MODEL NUMBER LABEL
5. FREQUENCY RANGE: 1600-5900 MHz
6. WEIGHT: 7.0 OZ

REVISIONS				
ZONE	REV.	DESCRIPTION	DATE	APPROVED
N/A	A-01	RELEASE TO MANUFACTURING	8/27/2013	DJG
N/A	B	DWG UPDATE	5/14/2021	CLQ

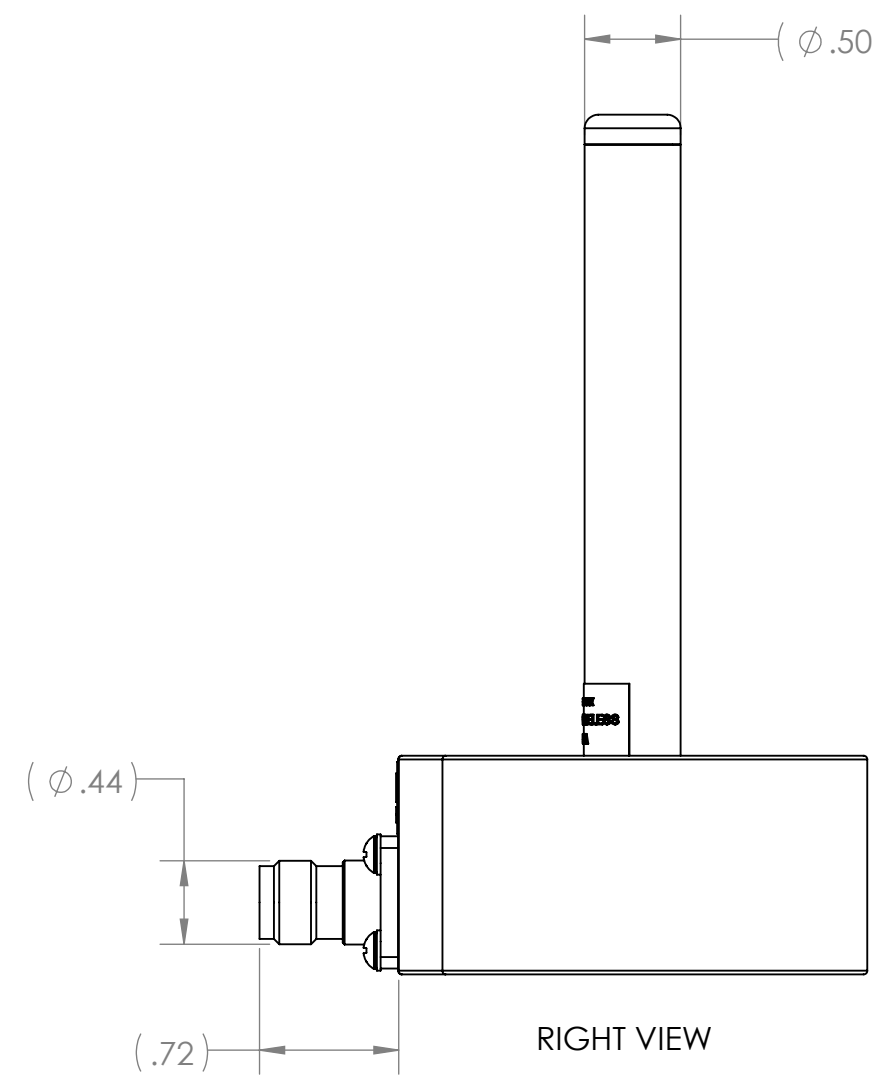
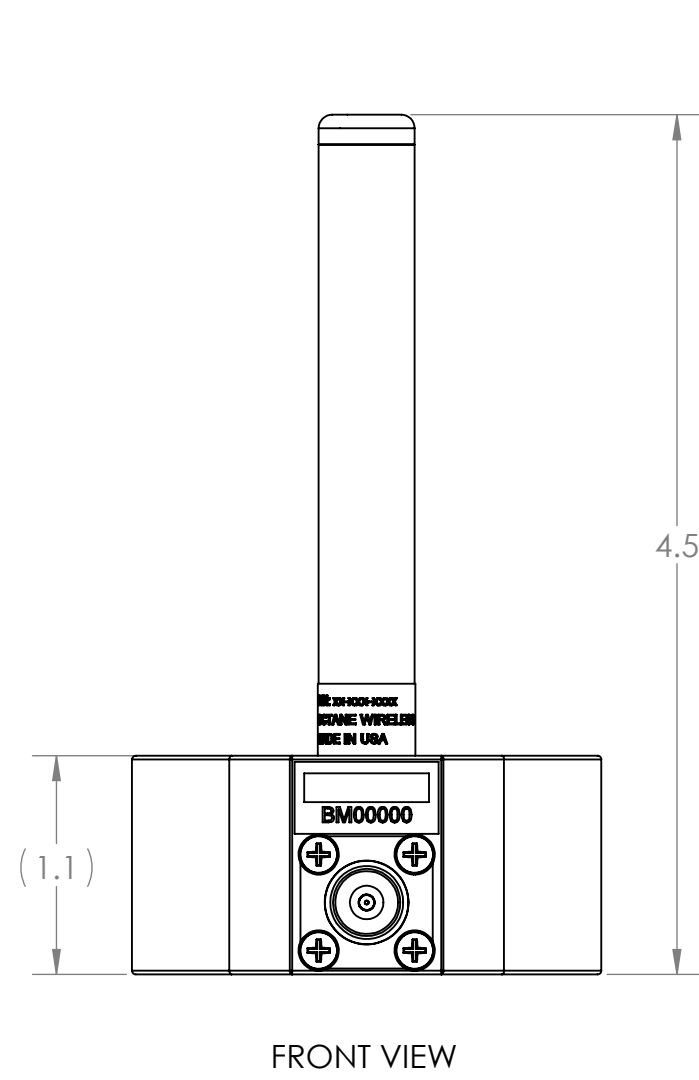
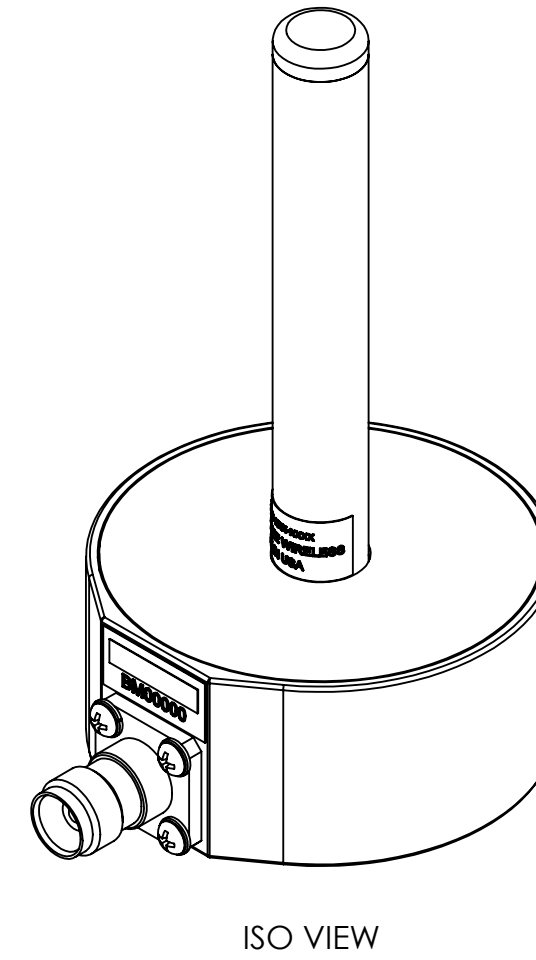
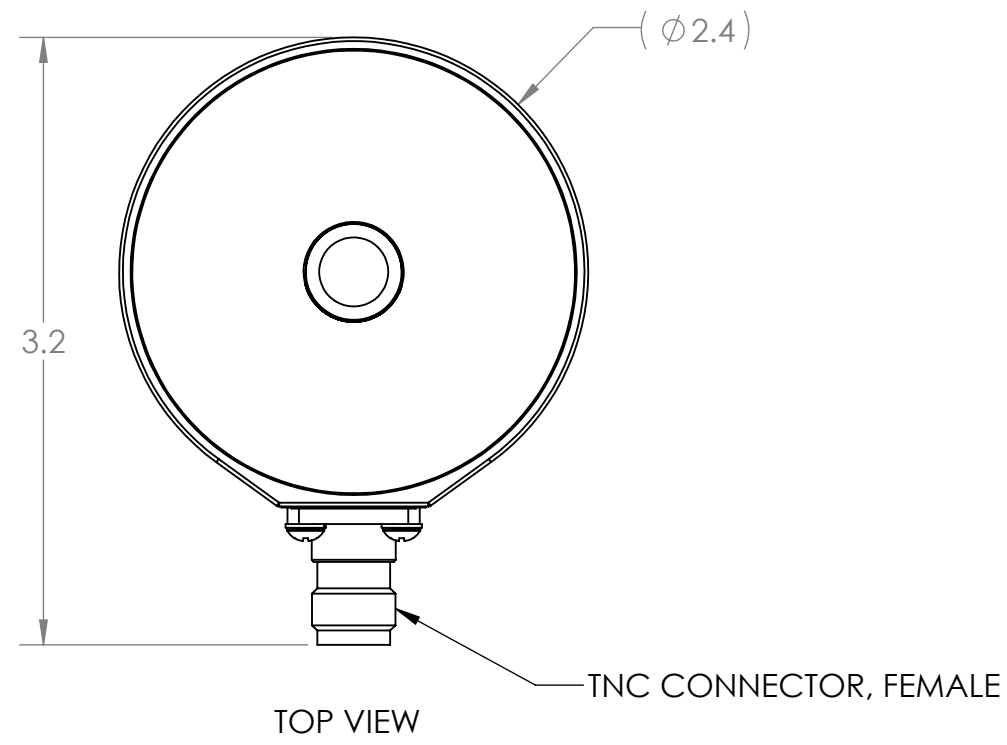

CAUTION: BASE CONTAINS STRONG MAGNETS

<p>THIRD ANGLE PROJECTION</p> <p>PROPRIETARY AND CONFIDENTIAL THE INFORMATION CONTAINED IN THIS DRAWING IS THE SOLE PROPERTY OF OCTANE WIRELESS. ANY REPRODUCTION IN PART OR AS A WHOLE WITHOUT THE WRITTEN PERMISSION OF OCTANE WIRELESS IS PROHIBITED.</p>	<p>UNLESS OTHERWISE SPECIFIED: DIMENSIONS ARE IN INCHES</p> <p>TOLERANCES: TWO PLACE DECIMAL ±.010 THREE PLACE DECIMAL ±.005 ANGULAR ±1°</p>	<table border="1"> <tr> <th>NAME</th> <th>DATE</th> </tr> <tr> <td>DRAWN JDM</td> <td>05/14/19</td> </tr> <tr> <td>CHECKED CLQ</td> <td>05/14/21</td> </tr> <tr> <td>ENG APPR. DN</td> <td>05/14/19</td> </tr> <tr> <td>MFG APPR. AF</td> <td>05/14/19</td> </tr> </table>	NAME	DATE	DRAWN JDM	05/14/19	CHECKED CLQ	05/14/21	ENG APPR. DN	05/14/19	MFG APPR. AF	05/14/19	<p>OCTANE WIRELESS 1340 CHARWOOD ROAD, SUITE L HANOVER, MD 21076</p>
	NAME	DATE											
	DRAWN JDM	05/14/19											
	CHECKED CLQ	05/14/21											
ENG APPR. DN	05/14/19												
MFG APPR. AF	05/14/19												
<p>MATERIAL SEE NOTES</p>	<p>COMMENTS:</p>	<p>TITLE: ASSEMBLY, MAGNET MOUNT, 1600-5900 MHz, TNC FEMALE CONNECTOR</p>	<p>SIZE DWG. NO. REV C VM-1600-5900-M B</p>										
<p>FINISH SEE NOTES</p>	<p>DO NOT SCALE DRAWING</p>	<p>SHEET SCALE 1:1</p>	<p>SHEET 1 OF 1</p>										