

NOTES:

1. OCTANE P/N: 103543
2. TRACEABILITY: OCTANE S/N
3. ALL DIMENSIONS IN PARENTHESES () ARE REFERENCE ONLY.
6. PART MARKING: OCTANE MODEL NUMBER LABEL
5. FREQUENCY RANGE: 700-3000 MHz
6. WEIGHT: 0.5 OZ

| REVISIONS | | | | |
|-----------|------|-------------|-----------|----------|
| ZONE | REV. | DESCRIPTION | DATE | APPROVED |
| N/A | A | DWG RELEASE | 5/18/2021 | BZG |

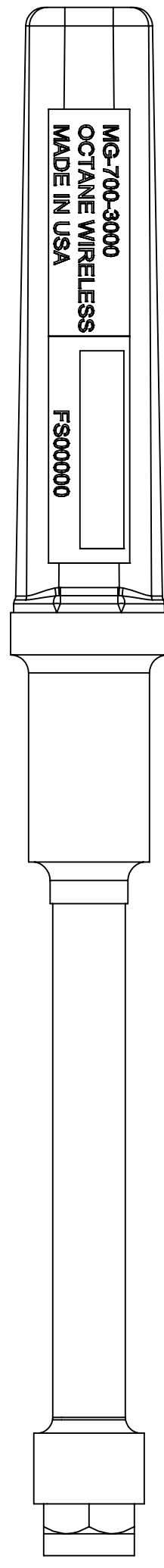

FRONT VIEW

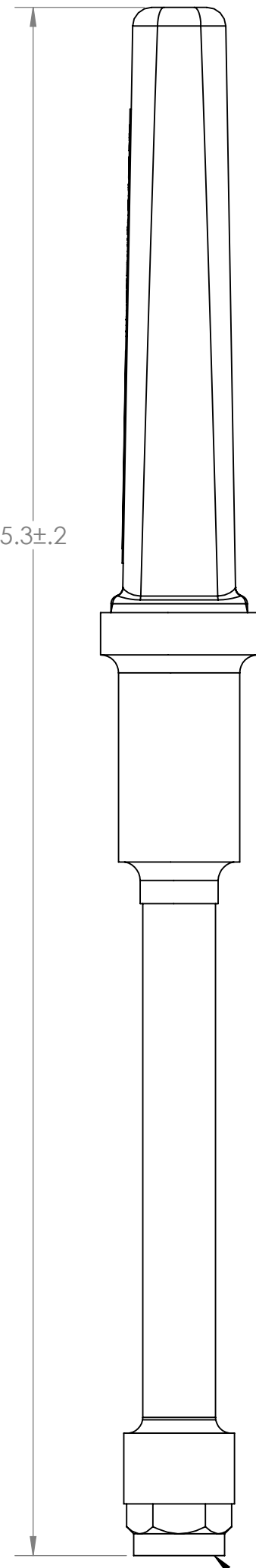

RIGHT VIEW

SMA CONNECTOR, MALE

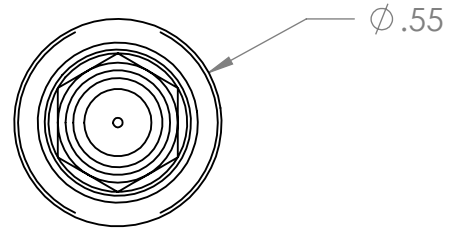

BOTTOM VIEW



ISO VIEW

THIRD ANGLE PROJECTION

PROPRIETARY AND CONFIDENTIAL
 THE INFORMATION CONTAINED IN THIS DRAWING IS THE SOLE PROPERTY OF OCTANE WIRELESS. ANY REPRODUCTION IN PART OR AS A WHOLE WITHOUT THE WRITTEN PERMISSION OF OCTANE WIRELESS IS PROHIBITED.

| | | | | |
|--|-----------|------|------------|---|
| UNLESS OTHERWISE SPECIFIED: DIMENSIONS ARE IN INCHES | DRAWN | NAME | DATE | OCTANE WIRELESS 1340 CHARWOOD ROAD, SUITE L HANOVER, MD 21076 |
| TOLERANCES: TWO PLACE DECIMAL ±.010 THREE PLACE DECIMAL ±.005 ANGULAR ±1° | CHECKED | BZG | 05/17/2021 | |
| MATERIAL | ENG APPR. | | | |
| FINISH | MFG APPR. | | | |
| DO NOT SCALE DRAWING | COMMENTS: | | | |

TITLE:
 ASSEMBLY, MINI-GOOSENECK
 ANTENNA, 700-3000 MHz

| | | |
|-----------------|-------------|--------------|
| SIZE | DWG. NO. | REV |
| C | MG-700-3000 | A |
| SHEET SCALE 2:1 | | SHEET 1 OF 1 |