

NOTES:

1. OCTANE P/N: 102946
2. TRACEABILITY: OCTANE S/N
3. ALL DIMENSIONS IN PARENTHESES () ARE REFERENCE ONLY.
6. PART MARKING: OCTANE MODEL NUMBER LABEL
5. FREQUENCY RANGE: 1700-1900 MHZ
6. WEIGHT: 0.5 OZ

REVISIONS				
ZONE	REV.	DESCRIPTION	DATE	APPROVED
N/A	A	DWG RELEASE	7/15/2019	BZG
N/A	B	DWG UPDATE	7/27/2021	CLQ

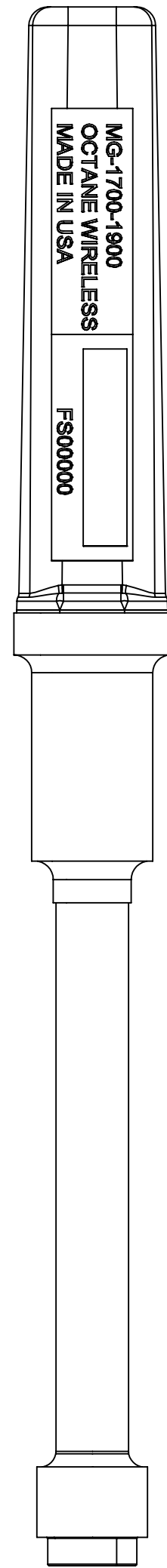

FRONT VIEW

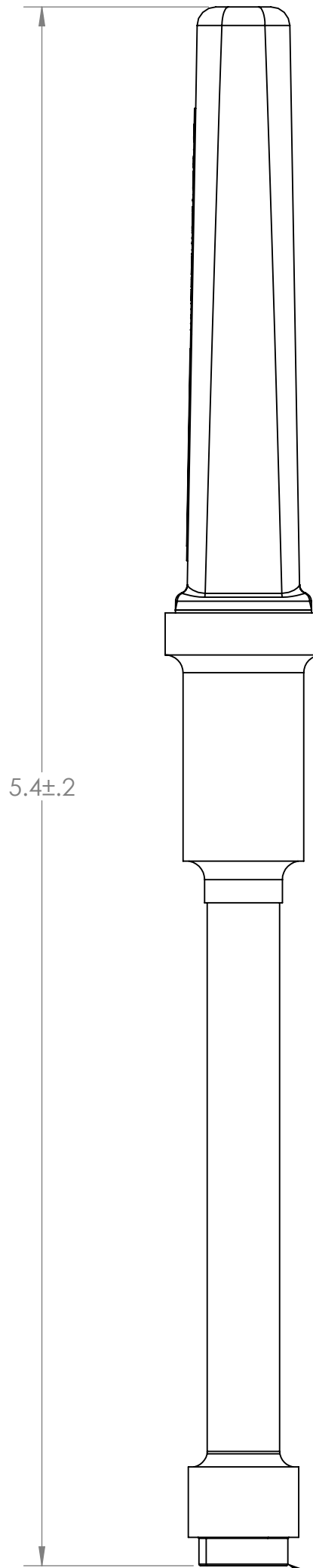

RIGHT VIEW

SMA CONNECTOR, MALE

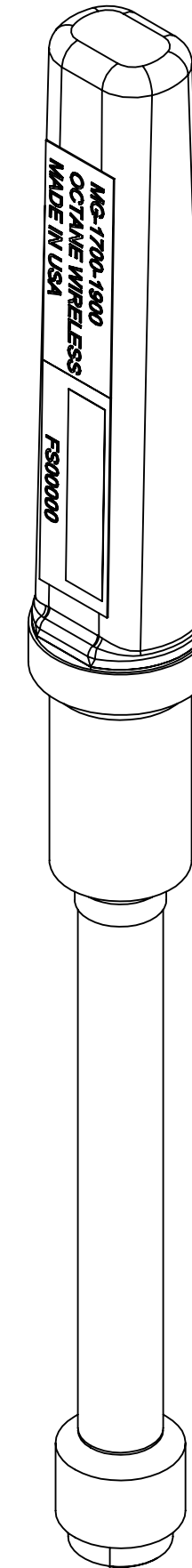

ISO VIEW

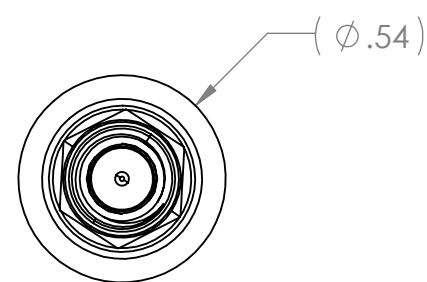

BOTTOM VIEW

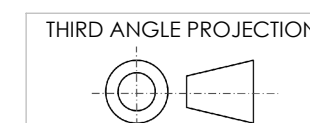

THIRD ANGLE PROJECTION
 PROPRIETARY AND CONFIDENTIAL
 THE INFORMATION CONTAINED IN THIS DRAWING IS THE SOLE PROPERTY OF OCTANE WIRELESS. ANY REPRODUCTION IN PART OR AS A WHOLE WITHOUT THE WRITTEN PERMISSION OF OCTANE WIRELESS IS PROHIBITED.

UNLESS OTHERWISE SPECIFIED: DIMENSIONS ARE IN INCHES	NAME	DATE	OCTANE WIRELESS 1340 CHARWOOD ROAD, SUITE L HANOVER, MD 21076
TOLERANCES: TWO PLACE DECIMAL ±.010 THREE PLACE DECIMAL ±.005 ANGULAR ±1°	DRAWN	BZG 07/15/19	
MATERIAL	CHECKED	CLQ 07/27/21	
FINISH	ENG APPR.	DN 07/15/19	
DO NOT SCALE DRAWING	MFG APPR.	AF 07/15/19	
COMMENTS:			TITLE: ASSEMBLY, MINI-GOOSENECK ANTENNA, 1700-1900 MHz, SMA MALE CONNECTOR

SIZE	DWG. NO.	REV
C	MG-1700-1900	B
SHEET SCALE 2:1		SHEET 1 OF 1