

1. OCTANE WIRELESS P/N:103237
2. TRACEABILITY: TAGGED WITH OCTANE WIRELESS S/N
3. PART MARKING: OCTANE WIRELESS PART NUMBER LABEL 102371-042
4. FREQUENCY OF OPERATION: 1350-1390 MHz
5. WEIGHT: 3.4 OZ

REVISIONS				
ZONE	REV.	DESCRIPTION	DATE	APPROVED
N/A	A	INITIAL RELEASE	2/4/2020	BZG
N/A	B	UPDATED CAP AND RADOME TO MATTE FINISH	5/3/2020	BZG

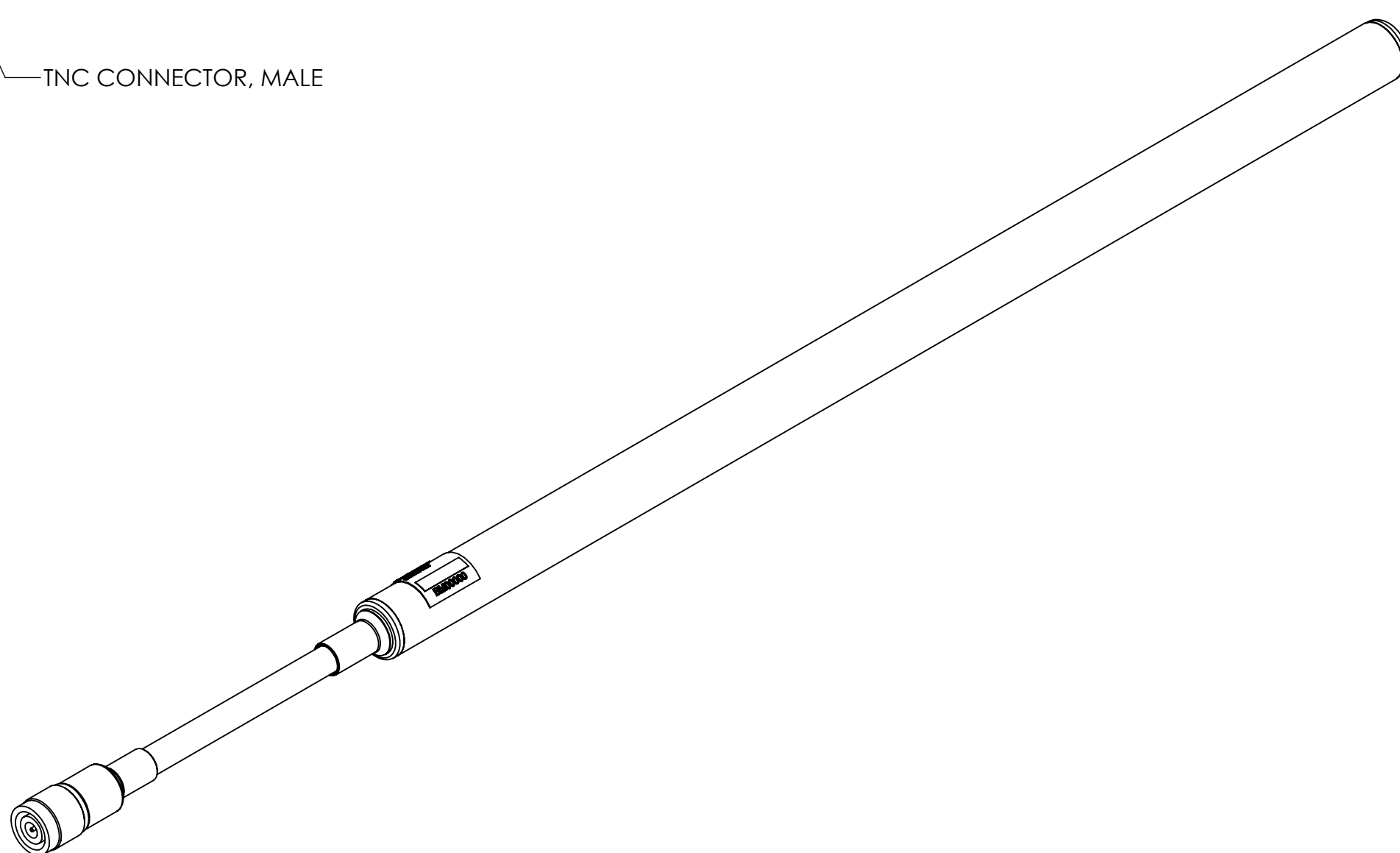
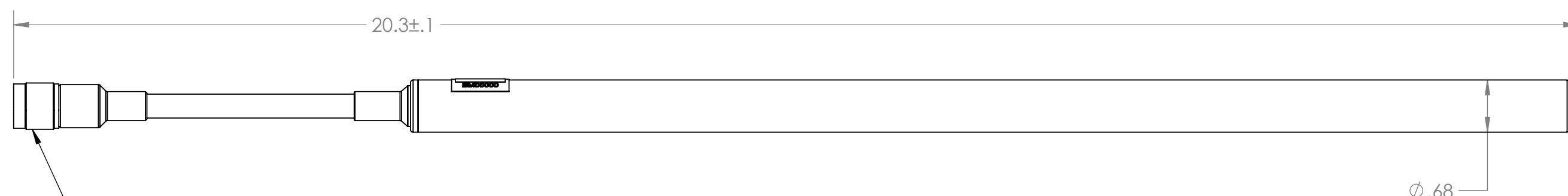

TNC CONNECTOR, MALE

PROPRIETARY AND CONFIDENTIAL
 THE INFORMATION CONTAINED IN THIS DRAWING IS THE SOLE PROPERTY OF PHARAD, LLC. ANY REPRODUCTION IN PART OR AS A WHOLE WITHOUT THE WRITTEN PERMISSION OF PHARAD, LLC IS PROHIBITED.

UNLESS OTHERWISE SPECIFIED:	NAME	DATE
DIMENSIONS ARE IN INCHES	DRAWN BZG	2/4/2020
TOLERANCES:	CHECKED	
TWO PLACE DECIMAL ±.010	ENG APPR.	
THREE PLACE DECIMAL ±.005	MFG APPR.	
ANGULAR ±1°	COMMENTS:	
MATERIAL		
SEE NOTES		
FINISH		
SEE NOTES		
DO NOT SCALE DRAWING		

OCTANE WIRELESS 1340 CHARWOOD ROAD, SUITE L HANOVER, MD 21076		
TITLE: ASSEMBLY, GOOSENECK ANTENNA, 1350-1390 MHz, VERTICAL POLARIZATION, 5 dBi		
SIZE	DWG. NO.	REV
C	GV-1350-1390 (5)	B
		SHEET 1 OF 1