

900 MHz ISM Wearable Antenna



Features

- 900 – 1000 MHz wearable antenna
- Waterproof cover
- Flexible material
- Unobtrusive – does not hinder vision or movement
- Small and lightweight
- Can be integrated with
 - Helmet
 - Body Armor Vest Carrier

Characteristics

Model Number	BW-900-1000
Frequency	900 – 1000 MHz
Gain†	0 dBi
Pattern	Near omni
Polarization	Vertical
VSWR†	< 2:1
Size	3.75" × 3.25" × 0.4"
Cable Length	16.0"
Weight	1 oz
Connector Type*	SMA Male

†Measurements done on phantom as surrogate body.
 *Alternate connectors available.

How to Buy

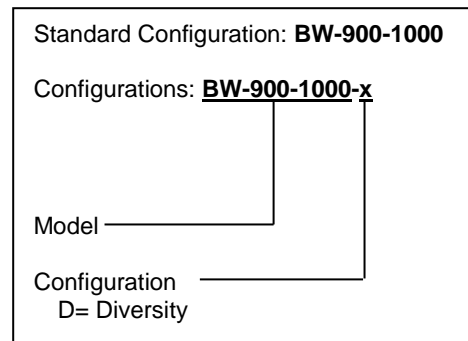

Radiation Patterns†

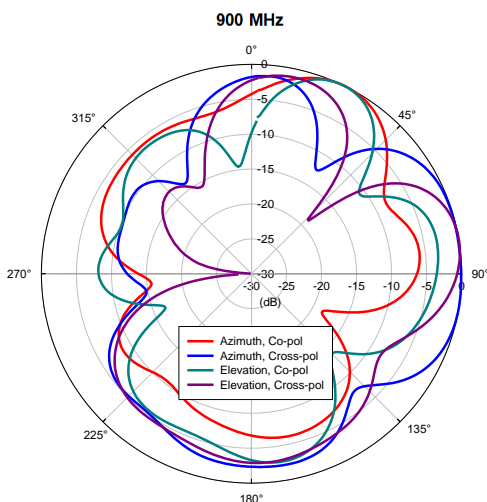

VSWR†

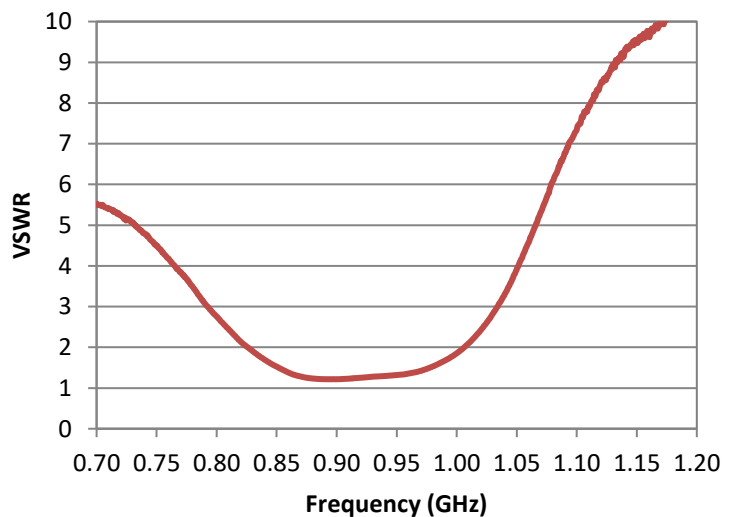

This antenna is intended for occupational use only and has been designed to comply with the IEEE (FCC) exposure limits for occupational/controlled RF exposure environments.

octane is a division of Pharad, LLC. Octane and Flexenna are registered trademarks of Pharad, LLC. Specifications subject to change without notice.

1340 Charwood Road, Suite L • Hanover, MD 21076 • phone 410-590-3333 • email info@pharad.com
www.pharad.com